

## PRODUCT DETECTOR BALANCED (DE-)MODULATOR

The product detector in our simple direct conversion radio takes two inputs

- Antenna RF input signal
- Variable frequency oscillator (VFO) RF signal

and combines them to product sum and difference frequencies (along with the original two frequencies). The sum will be an even higher radio frequency signal and we discard it by feeding it to a 50 resistor (a dummy load) through a capacitor (0.1 uF) that looks like a dead short at these high radio frequencies. (The original frequencies are attenuated due to the double balanced nature of our demodulator.)

The difference frequency, when we are tuned into a station, will be “base band” much lower frequency, an AUDIO frequency (300-3000 Hz) that when converted to sound, is something we can actually HEAR. We pass that through a significantly larger capacitor (on the order of 2 uF, something that has minimal reactance at audio frequencies.) to a 2,000 ohm input impedance common base amplifier in the input stage of the preamplifier.

### Magical Mixing

However, first we have to accomplish this magical “combination” that produces the sum and difference frequency. The mathematics of this is somewhat daunting, but the key fact is: all we need to do is pass these two radio frequency signals through SOMETHING NON-LINEAR (like a semiconductor device or vacuum tube). There are better and poorer choices, of course, but almost anything NON LINEAR will accomplish this “frequency multiplication.” Why this is called “multiplication” when it actually produces only *sum* and *difference* frequencies has to do with mathematics that we won’t touch at this stage.

### This happens more often than you think

When this signal-mixing is done by a rusty connection in a fence wire, or in an amplifier stage being driven into non-linear operation, we call it “**intermodulation distortion**” and we generally aren’t pleased. But in a receiver or transmitter, we frequently use a “mixer” that actually creates these sum and difference frequencies through a desired non-linear action using any of the following:

- a single diode
- a ring of four diodes
- a transistor amplifier
- a JFET or MOSFET amplifier
- a dual-gate MOSFET amplifier.

All of these have been used at some point in time and now there are integrated circuits that include ALL of this plus more right inside one little chip. But for the purposes of our little project, we are going to use a ring of four diodes.

The math of exactly HOW that accomplishes the sum and difference frequencies is a bit complicated. Suffice it to say that we desire to switch ON and OFF pairs of the diodes very sharply, driven by the variable frequency oscillator, and allow the tiny antenna signal to modify the exact moment of *turn on* and *turn off* by tiny bits of time – and the result will be the desired “mixing” of these frequencies.

### Avoiding unwanted outputs

We don't really want to pass the VFO frequency onto the preamplifier circuitry and we also don't want to pass the VFO signal back out to the ANTENNA (making a transmission of a steady carrier at our VFO frequency). For this reason we use a clever set of transformers that make our mixer be a “double-balanced” mixer.... And this tends to reject the unwanted signals from getting through this stage, and only pass the sum and difference newly created frequencies through.

In practice, testing a prototype of this mixer, I found that the rejection of the VFO signal was in the range of 30-50 dB rejection from appearing in the output of the product detector, or back out to the antenna. Not bad!! Meanwhile the “conversion efficiency” of the mixer stage is supposed to be in the range of -7 dB, meaning that the antenna signal of X dBm input strength will be converted to audio by the stage, but become 7dBm weaker in the process. Thankfully because of the relatively high levels of galactic noise and lightning crashes that are just everyday life on the HF bands, this isn't a significant limitation of our receiver. It is still plenty sensitive for our needs.

There are commercially-available mixer stages with built-in amplification that could even have a GAIN in the process of detection, but they may not have as large of a dynamic range as our simple diode mixer.

In order to build this diode detector ring, we have to create the input and output transformers. We do this by winding turns on a FT-50-43 ferrite core (outer diameter 0.50 inches; ferrite material #43) that significantly increases the inductance that the turns by themselves in air would have had. The permeability of our core (#43 ferrite material) is in the range of 800 so we get a very significant increase in inductance!

We need a transformer with a simple winding on one side, and a center-tapped winding on the other, in order to create our double-balancing. On one side of our mixer, the center tapped side will be the secondary; on the other side it will be the primary. But in winding our transformers we don't yet care about that.

***Building the two toroid transformers that we need takes less than 15 minutes, once you understand the directions. But it took me about 4 hours to write this set of explanations/instructions.***

The figure below illustrates the effective transformer windings we wish to obtain, for simplicity only showing TWO TURNS. The figure is in color in the original and it is recommended that the reader find this document in PDF so the colors can be appreciated:

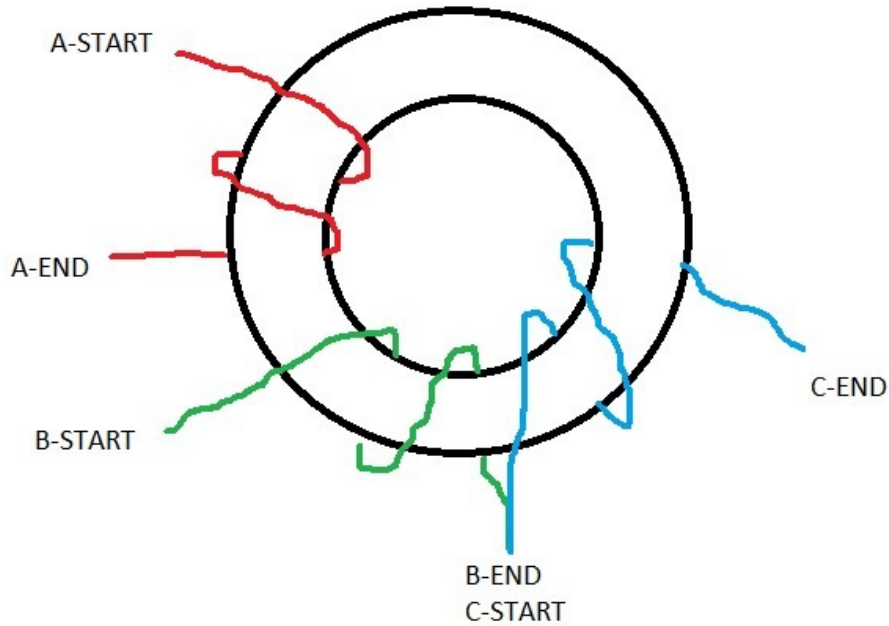

In this drawing, the non-center-tapped winding is “A” and it has a *start* and *end*.

The B winding proceeds with the same direction of turns about the core, and joins the C winding in order to make the “center tap” which is precisely the center, because the B and C windings have exactly the same number of turns.

#### How To Count Turns

In winding toroids, every time we go through the center, we count that as a turn. So if you look closely at the drawing, the A winding, B winding and C winding all have exactly 2 turns. (We are going to actually put 10 – 13 turns on our transformer but that is too difficult to draw here.)

The B and C windings put together have 4 turns in the drawing above.

#### Transformer Action

An incoming voltage on the A winding will create exactly the same voltage on the B winding – and also on the C winding. Therefore the voltage on the B+C windings connected together will be TWICE the voltage (of that on the A winding). Since power can’t be created out of thin air, the power on the output can’t be any greater than the power on the input, so the current on the output (B+C) will be  $\frac{1}{2}$  of the current on the A input – and the impedance of the output will be voltage/current = (twice the input voltage) / (half the input current) or four times greater – so this transformer can step up a 50 ohm impedance into 200 ohms – or vice versa it can drop 200 ohms down to 50.

And that is exactly what we do with these transformers.

The input transformer takes 50-ohm input signals and steps them up to a higher voltage and lower current compatible with 200 ohm circuitry for the diodes; the output transformer takes the output signal and reduces the voltage and increases the current to step it down to a 50 ohm environment.

The reason we do this is to make the diodes function better since they require reasonable voltages (0.6 volts) to switch ON. Our VFO is thus better able to switch these diodes rapidly ON and OFF.

### WINDING THE TOROIDS

We don't actually wind the toroids in the simplistic manner shown in the drawing. In order to have really tight magnetic coupling between the primary and secondary sides of these transformers we actually twirl the wires together into a three-filament ("tri-filar") cord and wind the transformer with that three-wire cord. That gives us very high coupling between the input and output.

The problem comes in identifying the A, B, and C wires so that we make the proper connections.

Note that the END of the B wire needs to connect to the BEGINNING of the C wire. **Look at the drawing above until this is clear.**

### Use Enamel or Tinning As A Marking

The wire that we use has an enamel coating that can be burned away by drawing it through a hot blob of solder on the end of a soldering iron. We'll use this to "mark" our three wires, **each cut to 10-1/2"**.

A wire – no tinning at all on either end (remains enameled)

B wire – we will create a 3/4" - 1" tinned section of wire (enamel burned off and solder tinning the wire) on both ends.

C wire – we will create a tiny 1/4" tinned section of wire on both ends

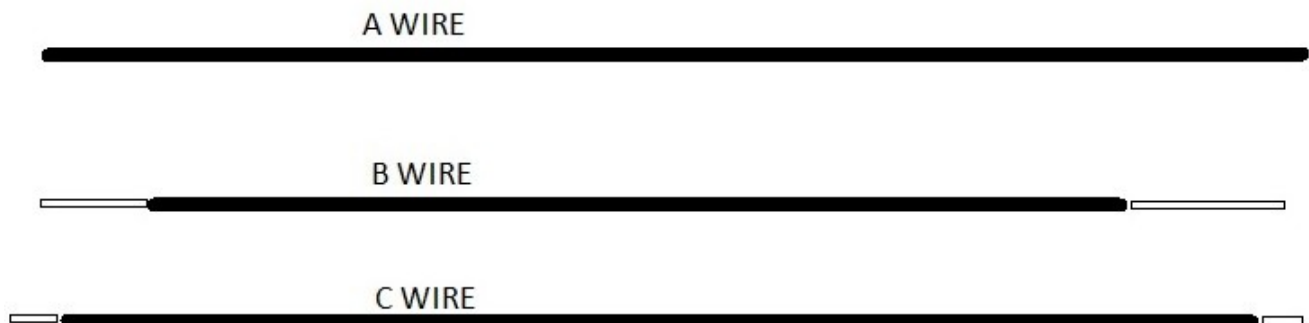

Then using either simple manual twirling or a slow-turning electric drill, we twirl the three wires into a cord, with about 6-8 turns per inch.

Now pass the cord of wires through the center of the toroid, leaving about 1-1/4" inch outside at the "start" of the windings, just enough so there is enamel insulated wire from B still showing, and fairly tightly wind 10-13 turns on your transformer, ending up with at least 1 to 1-1/2 inches at the far end (it is OK to have too much, not OK to not have enough to work with). I wind from "left" to "right" but it doesn't matter how you do this. Because all the wires were twirled into a trifilar cord, they all were wound with the same "sense". Now all we have to do is connect the proper end of B to the proper beginning of C and our transformer will be done.

Put your "START" end to the left, and the "END" end on the right. It doesn't matter whether your windings were "over" or "under-handed" so don't worry about that part.

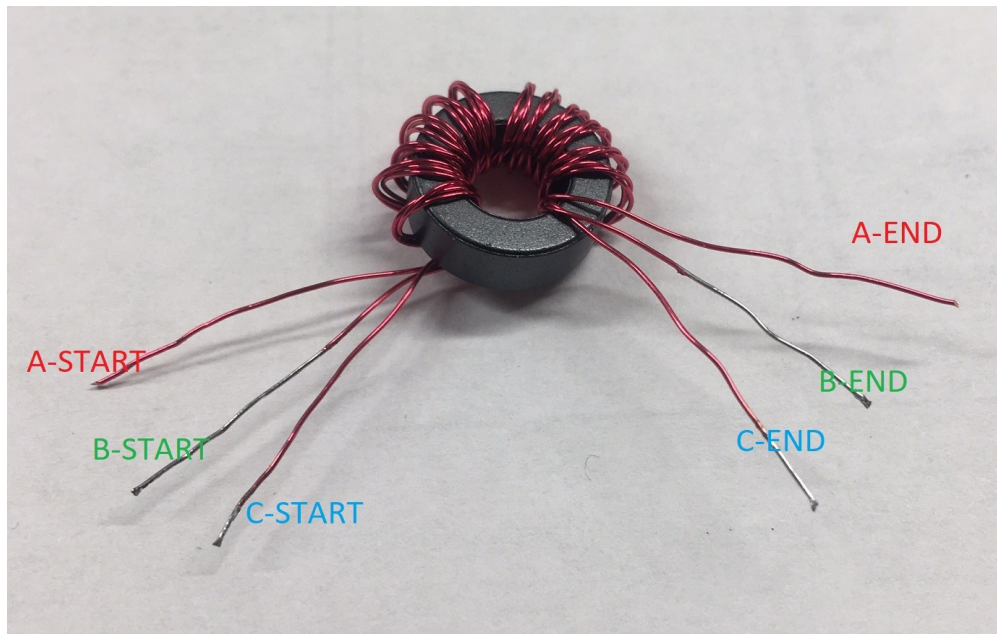
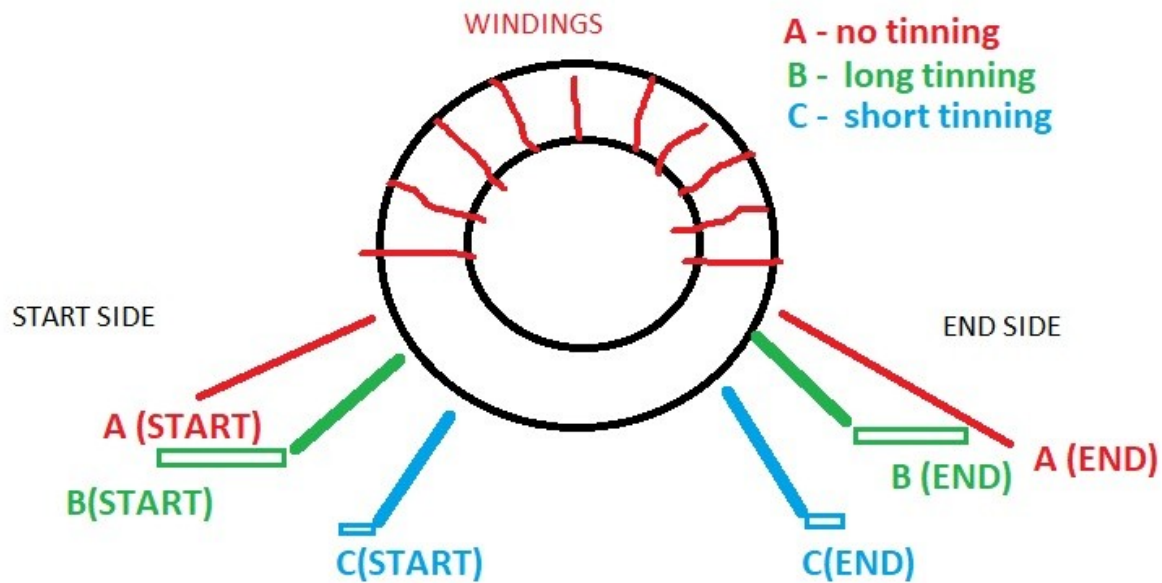

Now comes the important part. We're going to tie the C (start) winding to the B (end) winding so that we have the B and C connected in the proper phasing and we end up with nice center tapped winding.

Take the short-tinned C START, and twist a turn or two around the B-ENDING wiring, right on the tinned portion just after the tinning begins. Solder the two together. You have now created a 20-26 turn center tapped winding "BC" that has a nice center tap!

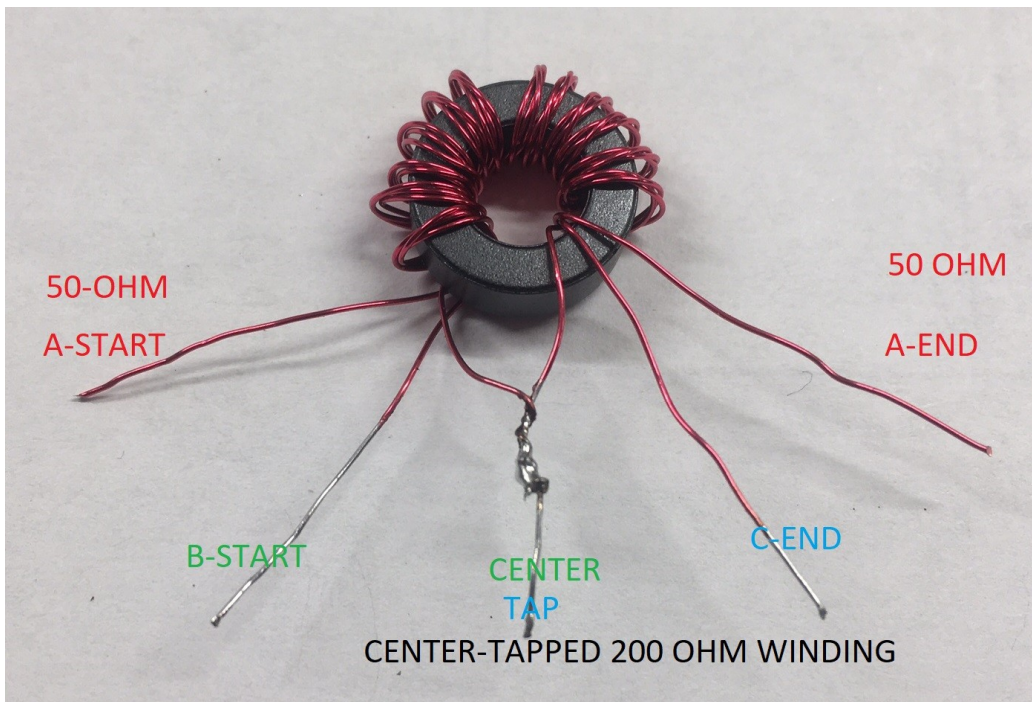
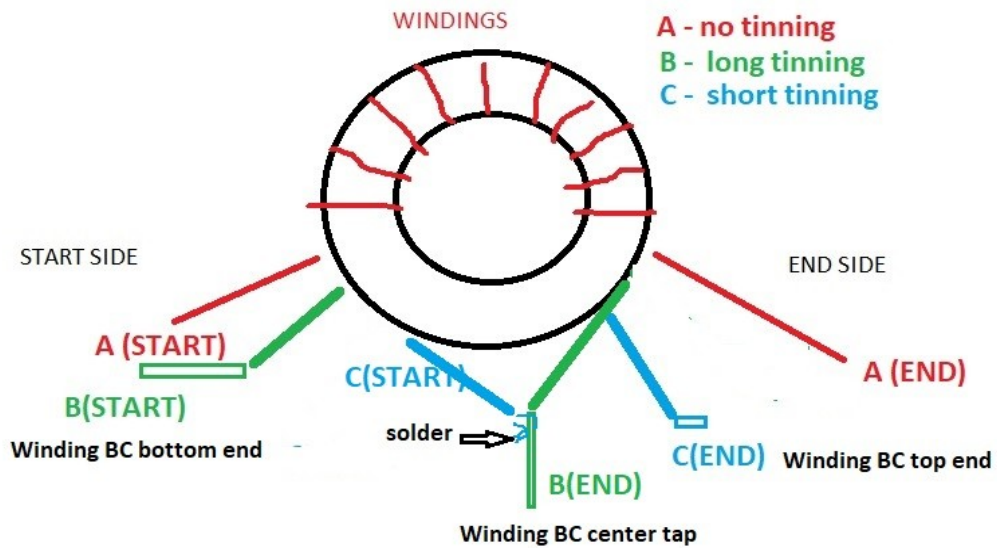



We can now use this type of transformer as either a step-up (with a center tapped secondary) or a step-down (with a center tapped primary) impedance transformer. See the drawings below:

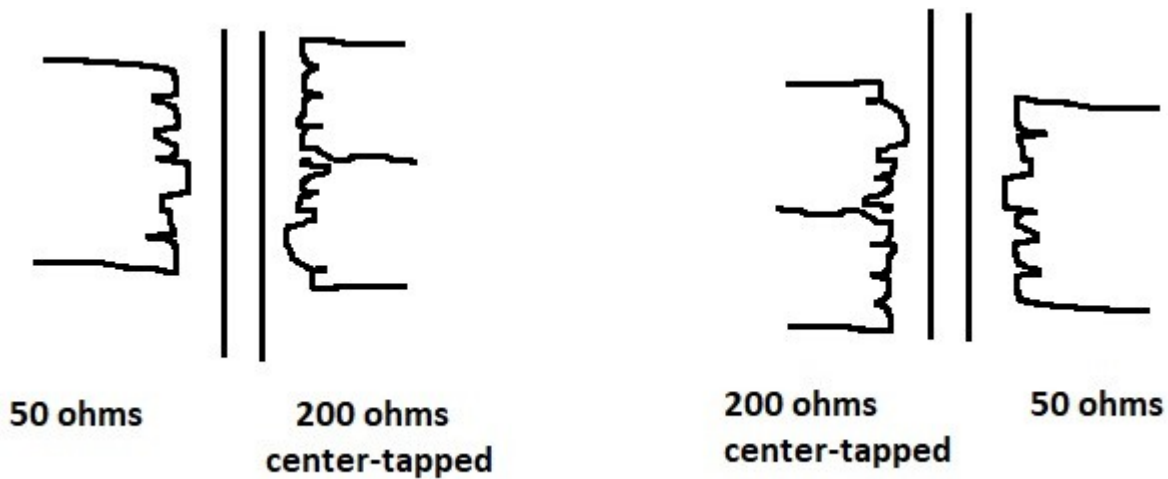

The lower-impedance side has 10-13 turns and the higher-impedance side has 20-26 turns, depending on how many “fit” on your toroid.

You may now need to adjust the length of some of your wires, but keep all the wires going the right places – keep your A wires separated from your B – BC – C center tapped secondaries.

In our balanced modulator circuit there is no connection “across” the transformer; the low impedance side and the high impedance side have no other feedback or cross-transformer connections. So the exact phasing of the primary versus the secondary is not important, and it no longer matters for you to keep the “start and end” distinct on either the low or high impedance side. What counted was that we had the high impedance winding with two halves properly phased so the center tap gets half of the total voltage between the two ends. (If you wired the two half-windings in reverse, their voltages would have canceled and you’d get NO voltage between the beginning and ending!)

You have to have TWO of these toroidal transformers so if you haven’t already been building the second one at the same time, now repeat the instructions and build the second toroid.

You can now wire the two toroids into the two ends of the balanced modulator circuit as shown in the illustration below:

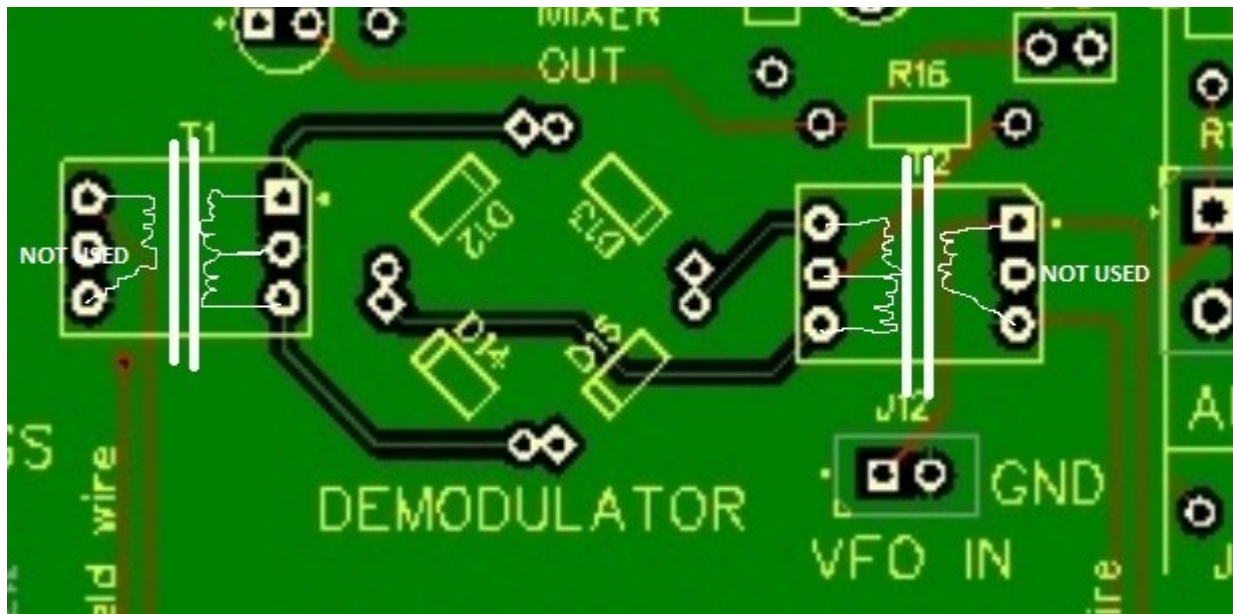

Note that the center-tapped high impedance winding side goes closest to the demodulator diodes on both sides. The lower-impedance (non center tapped) side goes to the OUTSIDE away from the demodulator diodes. The middle solder pad on the lower impedance (outside) side is not used.

### **DIODE RING**

Finally you will solder in the four matched diodes for the ring. Either your instructor or your team will have “matched” diodes for approximately the same forward voltage drop at a modest current. This makes the double-balanced mixer have a better performance and balance. Some more complicated mixer will have either a split variable capacitor and/or a potentiometer across some of the circuit to even better balance the demodulator but for our simple receiver we won’t need this.

A simple circuit to measure the forward voltage drop of about 10 diodes all receiving the same current can be made by arranging up to 10 or 12 diodes in series, all the same direction, and using a series 10Kohm resistor to feed them from a 12volt source. The diodes will add up to about 6-7 volts drop, and the 10K resistor will then allow about ½ milliampere to flow from a 12 volt source. Read the voltage right across each diode with a sensitive digital voltmeter and record for each individual diode. Pick diodes that have just about the same voltage drop (down to the nearest millivolt) and you should be good.

DIODES HAVE POLARITY – there is an ANODE end and a CATHODE end – the Cathode end has a painted ring or BAR on its end of the glass or plastic diode. On the diode case symbol on the printed circuit board one end has the same BAR shown. Be certain that you match the BAR on the physical diode with the BAR on the screen printing of the printed circuit board.

Don’t overheat the diodes when soldering them in.



Your instructor will explain what your build group will do with the option on the board to add a BANDPASS Filter, and to add back-to-back protection diodes on the input of your Receiver.